



# **CABINET PARTS SECTION**



## READING A PARTS LIST

- I **ITEM NUMBER** is found in two locations:
    - A. It is on the drawing plate, and identifies the part and its location;
    - B. The same number is in the parts lists and ties the two together.
  - II **PART NUMBER** is the part number that has been assigned to a specific part by Vendo, for easier identification.
  - III **QUANTITY REQUIRED** relates to the amount required of a part, or will be indicated by "A/R" (as required) to attach it to another part.
  - IV **PART NAME AND DESCRIPTION** is the general description for the part, for easier identification when ordering a like part.
  - V **HARDWARE** is identified by a letter in a hexagon. Refer to hardware list section or description and part numbers. See pages C-4 and C-5.
- 

The example below will show how the parts are listed in the parts lists:

- 1. **VEND MOTOR ASSEMBLY:** This is the main assembly name, and any replaceable parts will be indented below the assembly.
- 2. **RETAINER CAM:** This is an individual part, and will be indented. These indented parts can be ordered separately, so you do not need to order the entire assembly.
- 3. Whenever an assembly is ordered, all the parts that are indented will be included in the assembly. Any hardware will be listed next to their corresponding parts.
- 4. Any parts that may be ordered separately will not have any indented parts listed below them.

ITEM NO	DESCRIPTION	QTY REQ	PART NO.
1	VEND MOTOR ASSEMBLY	~	1115821
2	RETAINER CAM	1	1113244
3	TIMING CAM	1	1113236













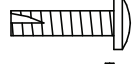

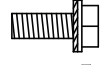

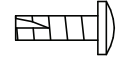

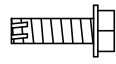



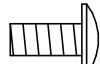



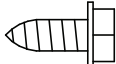

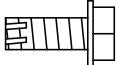

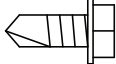

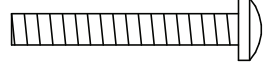



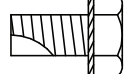

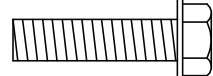
If an asterisk is listed below the parts list, it is an indication that special information is noted. There may be more than one asterisk (\*) (\*\*) (\*\*\*) denoting special notes.

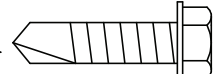

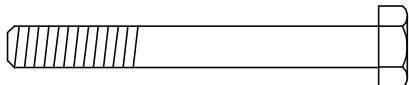

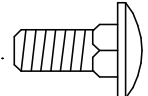

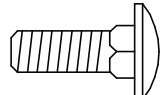



















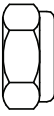
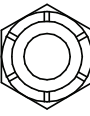

Purposely left blank

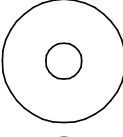

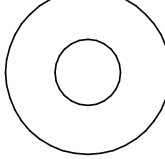
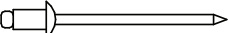
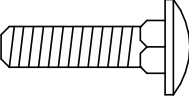
## HARDWARE LIST

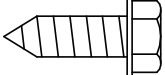
	PART NO.	DESCRIPTION	PICTORIAL
A	V800762	#8 X 5/16" TAPPING SCREW	 
B	V802139	#8 X 5/8" TAPPING SCREW	 
C	V800586	#8 X 3/8" TAPPING SCREW W / LOCK WASHER	 
D	V802214	#8 X 1/2" TAPPING SCREW (FOR PLASTIC)	 
E	V801475	#8 X 1/2" TAPPING SCREW	 
F	V801421	#10 X 5/16" TAPPING SCREW	 
G	V802212	#10 X 3/8" TAPPING SCREW	 
H	V802047	#10 X 5/16" TAPPING SCREW W / LOCK WASHER	 
I	V802141	#10 X 1/2" TAPPING SCREW	 
J	V801422	#10 X 1/2" TAPPING SCREW	 
K	V801489	#10 X 1/2" SELF DRILLING SCREW	 
L	V800512	#10 X 1-3/8" TAPPING SCREW	 
M	V802115	#10 X 1" BOLT	 
N	V801360	1/4" X 1/2" TAPPING SCREW W / LOCK WASHER	 
O	V801343	1/4" X 1" TAPPING SCREW	 
P	V801490	1/4" X 1" SELF DRILLING SCREW	 
Q	V802053	1/4" X 2-1/4" BOLT	 
R	V802069	1/4" X 5/8" CARRIAGE BOLT	 
S	V801434	1/4" X 3/4" CARRIAGE BOLT	 



T	V800267	1/4" X 3/8" BOLT .....		
U	V800956	#8 NUT W / LOCK WASHER .....		
V	V800952	#10 NUT W / LOCK WASHER .....		
W	V802111	#10 HEX NUT .....		
X	V802113	#10 LOCK NUT W / NYLON INSERT .....		
Y	V800959	1/4" NUT W / LOCK WASHER .....		
Z	387925	1/4" LOCK NUT W / NYLON INSERT .....		
AA	V802062	3/8" LOCK NUT W / NYLON INSERT .....		
AB	V801013	#10 FLAT WASHER .....		
AC	389026	#10 FLAT WASHER, LARGER O.D. ....		
AD	V801491	3/8" FLAT WASHER .....		
AE	V801412	1/8" POP RIVET .....		
AF	V801435	1/4" 20 X 1" CARRIAGE BOLT .....		
AG	V802220	1/4" X 3/4" TAPPING SCREW .....		
AH	1123719	SPACER .....		

1

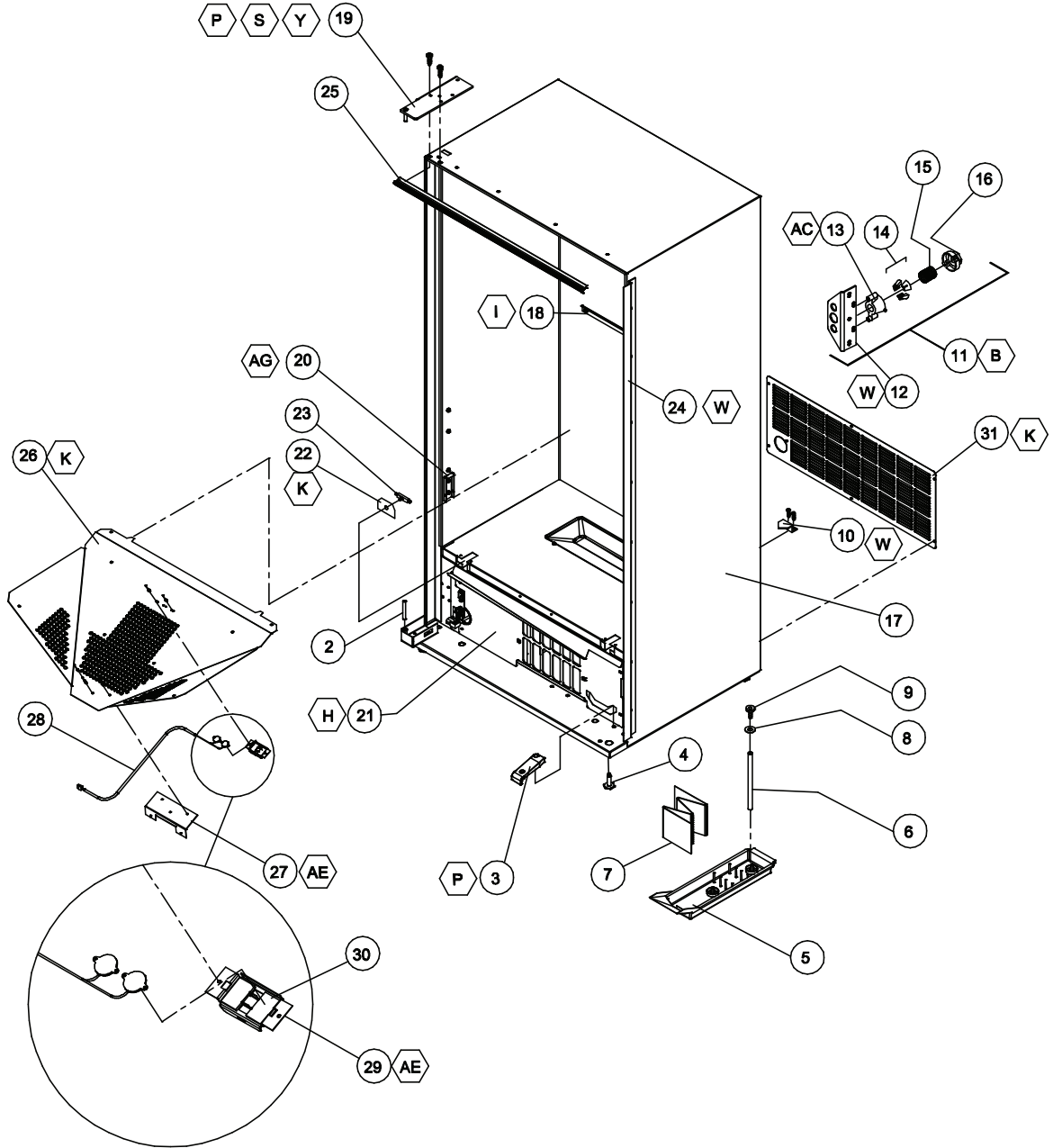



## CABINET ASSEMBLY

ITEM NO	DESCRIPTION	QTY REQ	PART NO.
1*	CABINET ASSEMBLY - FOAMED	1	~
2	HINGE PIN	1	389071
3	RAMP	1	1120387
4	LEVELING LEG	1	1059902
5	CONDENSATE PAN	1	1122475
6	DRAIN TUBE	1	1088449-1
7	FIBERGLASS EVAPORATOR BOARD	1	1122728
8	DRAIN TUBE GASKET	1	387837
9	DRAIN TUBE FUNNEL	1	1068678
10	BRACKET - REFRIGERATION	2	1123527
11	QUICKER LOCK ASSEMBLY	1	1123724
12	LATCH BRACKET	1	1123675
13	NUT RETAINER HOUSING	1	1123689
14	NUT SEGMENT	3	1033085
15	SPRING	1	389690
16	CAP	1	1111988
17**	SIDE DECAL	2	**
18	STACK SUPPORT	1	1123018
19	TOP HINGE	1	2000805-03
20	BRACKET STACK SUPPORT	2	1079007
21	AIR DAM/KICK PANEL ASSEMBLY, 39"	1	1123440
~	AIR DAM/KICK PANEL ASSEMBLY, 32"	1	1123440-1
22	DOOR SWITCH BRACKET	1	1121043
23	DOOR SWITCH	1	323007
24	OVERLAPPING DOOR GUARD - 72"	1	2001376
~	OVERLAPPING DOOR GUARD - 79"	1	2002325
25	SEAL, 39"	1	1122500
26	VEND CHUTE, 39"	1	1123453
~	VEND CHUTE, 32"	1	1123451
27	CHUTE BRACKET	1	1077864
28	DROP SENSOR	1	1122923
29	DROP SENSOR MOUNTING BRACKET	1	1123601
30	FOAM PAD, DROP SENSOR	2	1123654
31	SAFETY SCREEN, 39"	1	1122568
~	SAFETY SCREEN, 32"	1	1122568-1

\* NOTE: WHEN ORDERING CABINET ASSEMBLY, PLEASE PROVIDE **9-CODE** OR **11-CODE** AND **MANUFACTURER'S DATE CODE**.

\*\*NOTE: WHEN ORDERING DECALS, PLEASE PROVIDE **STYLE**.

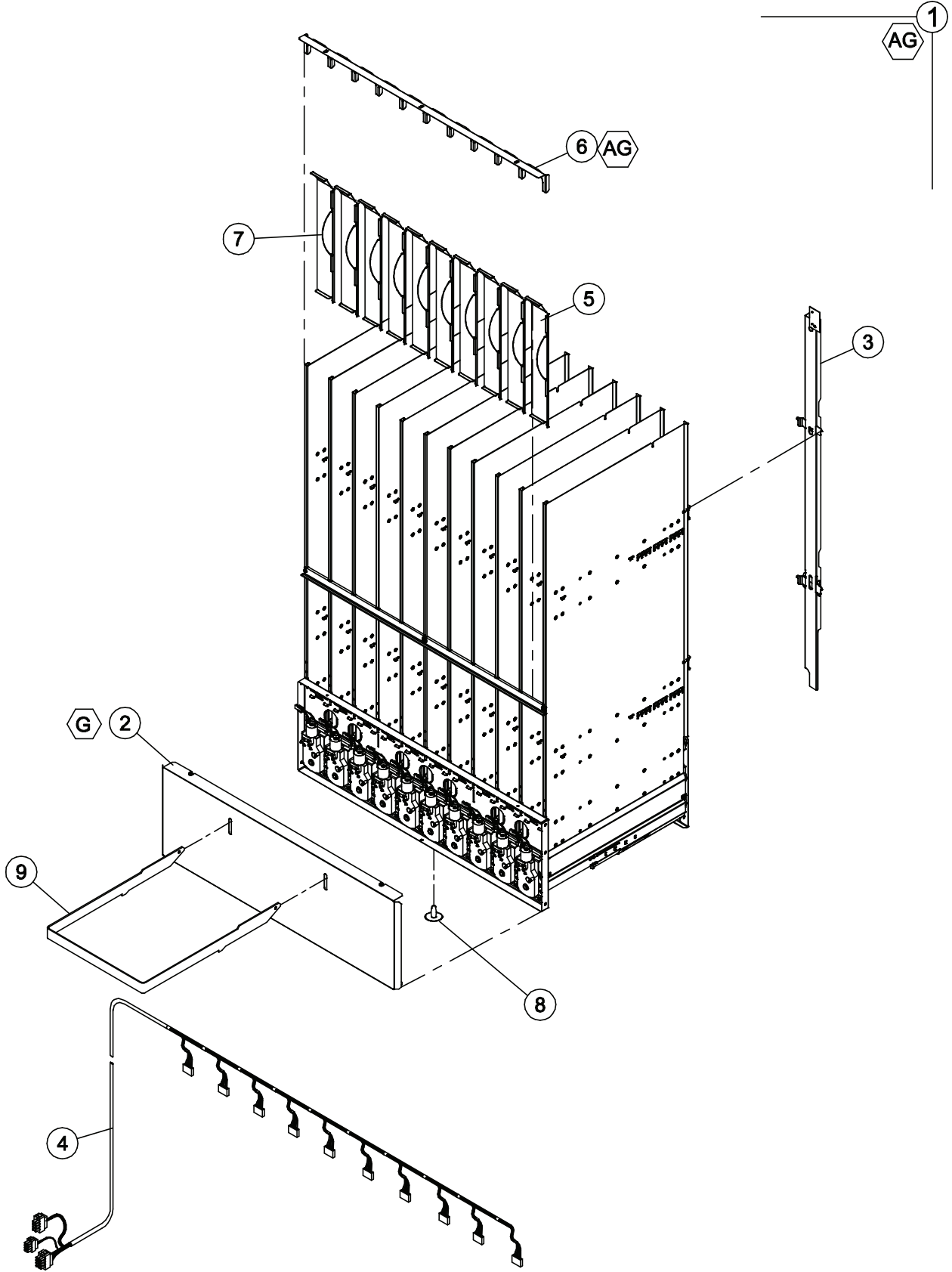





## STACK ASSEMBLY

ITEM NO	MODEL NUMBER		721	821	621
	DESCRIPTION	QTY REQ	PART NO.	PART NO.	PART NO.
1	STACK CHASSIS ASSEMBLY	1	1123591-02	1123591-03	1123591-01
2	MOTOR COVER	1	1123003	1123003	1123037
3	BACK SPACER ASSEMBLY	*	1123047-1	1123047	1123047-1
4	MOTOR HARNESS	1	1122918	1122918	1123050
~	MOTOR HARNESS W/ PRE-COOL	1	1124065	1124065	1124066
5	LOWER RETAINER	*	1124868	1124868	1124868
6	TOP STACK STRAP	1	1122809	1122809	1123039
7	FRICTION WIRE	*	1123347	1123347	1123347
8	SNAP IN PLUG	1	V802043	V802043	V802043
9	LOADING RACK	1	1123662	1123662	1123662

\*MODELS 721 & 821 USE 10 EACH.  
 MODEL 621 USES 8 EACH.

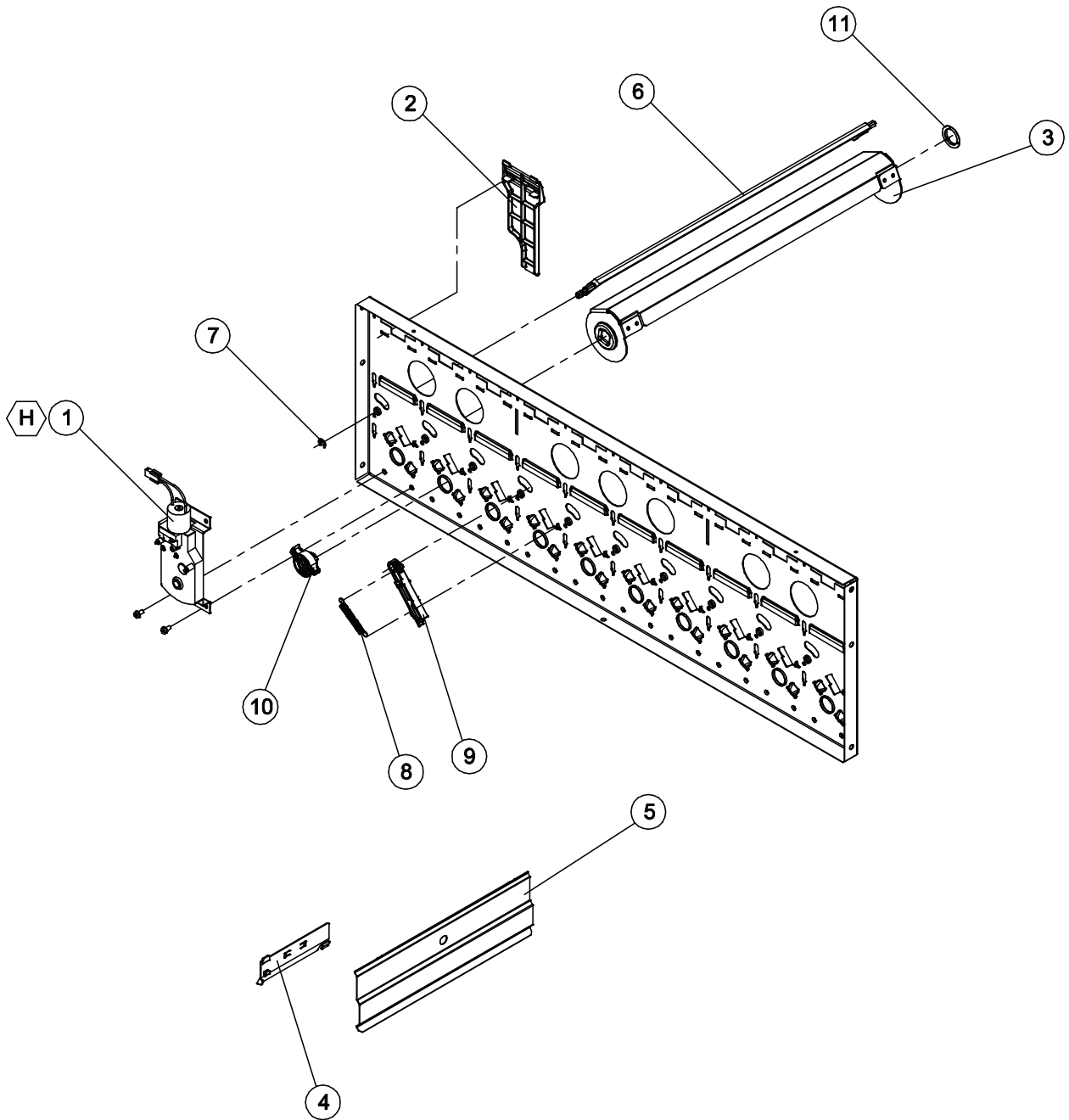



## MECH PLATE ASSEMBLY

ITEM NO	MODEL NUMBER	721/821		621	
	DESCRIPTION	QTY REQ	PART NO.	QTY REQ	PART NO.
1	VEND MOTOR ASSEMBLY	10	1122820	8	1122820
2	FRONT SPACER	10	1122814	8	1122814
3	VEND BUCKET	10	1122815	8	1122815
4	CAN CLIP	10	1122856	8	1122856
5	* PRODUCT SPACER, 2.4 DIA	AR	1122928	AR	1122928
6	GATE	10	1122818	8	1122818
7	E-CLIP - GATE	10	V801080	8	V801080
8	SPRING	10	390326	8	390326
9	GATE LINK	10	1122819	8	1122819
10	COUPLING CAM	10	1122817	8	1122817
11	REAR BUSHING	10	1122816	8	1122816

\*DEPENDING ON PRODUCT

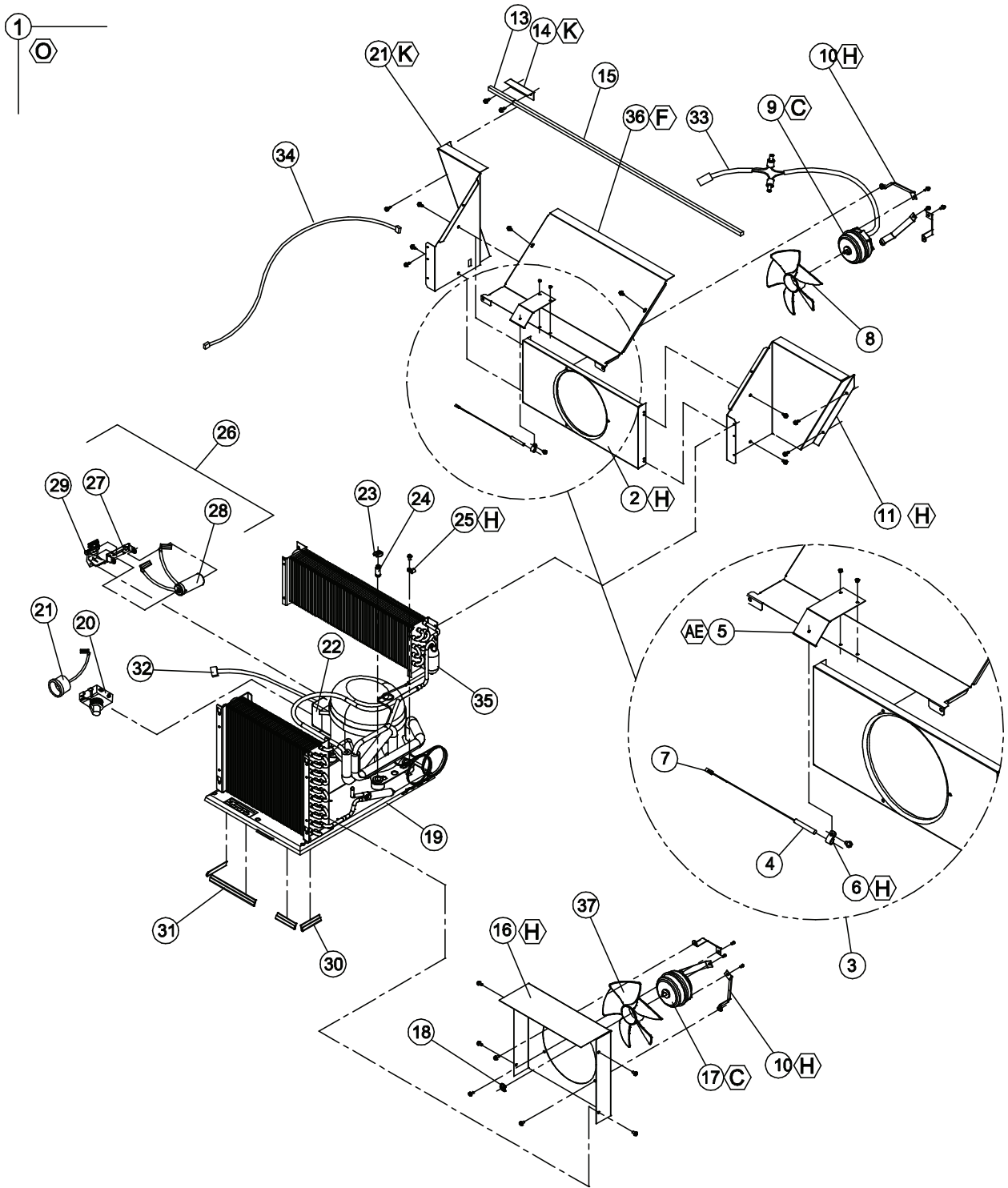



## REFRIGERATION ASSEMBLY

ITEM NO	DESCRIPTION	QTY REQ	PART NO.
1	REFRIGERATION ASSEMBLY D90 TE S 1/3 R134a CAP START	1	1123589
2	ORIFICE PLATE, SINGLE FAN	1	390228
3	TEMPERATURE SENSOR ASSEMBLY	1	1124254
4	TEMPERATURE SENSOR	1	1122924
5	TEMPERATURE SENSOR BRACKET	1	1124156
6	CLAMP, 1/4"	1	324099-2
7	PUSH MOUNT CLAMP	1	384692
8	EVAPORATOR FAN BLADE	1	1113562
9	FAN MOTOR - EVAPORATOR	1	42321-17
10	BRACKET - FAN MOTORS	6	1117996
11	RIGHT AIR BAFFLE - EVAPORATOR	1	1123564
12	SMALL AIR DUCT - EVAPORATOR	1	1124097
13	FOAM TAPE, 3.5"	1	1124421-2
14	EVAPORATOR EXTENSION BRACKET	1	1124158
15	FOAM TAPE, 32.5"	1	1124421
16	CONDENSER DUCT	1	1122413
17	FAN MOTOR - CONDENSER, 115V	1	1121770
18	FAN MOTOR CLIP - CONDENSER	1	V42323
19	BASE - REFRIGERATION	1	1122470
20	START RELAY (PART OF ASSY 513506066)	1	--
21	OVERLOAD PROTECTOR (PART OF ASSY 513506066)	1	--
22	COVER - OVERLOAD (PART OF ASSY 513506066)	1	--
23	CLIP - COMPRESSOR MOUNT	2	343874
24	STUD - COMPRESSOR MOUNT	2	390102
25	CLAMP, 5/16"	1	324099-3
26	CAPACITOR ASSEMBLY	1	1112805
27	BRACKET - CAPACITOR	1	1112848
28	CAPACITOR-START/END	1	1122999
29	CAPACITOR CLIP	1	1076481
30	EDGE TRIM - SHORT	3	388304-1
31	EDGE TRIM - LONG	1	388304-3
32	COMPRESSOR POWER HARNESS	1	1121019-1
33	EVAPORATOR FAN HARNESS	1	1122193
34	EVAPORATOR POWER HARNESS	1	1124185
35	EVAPORATOR	1	1122235
36	EVAPORATOR COVER	1	1124099
37	CONDENSER FAN BLADE	1	389614

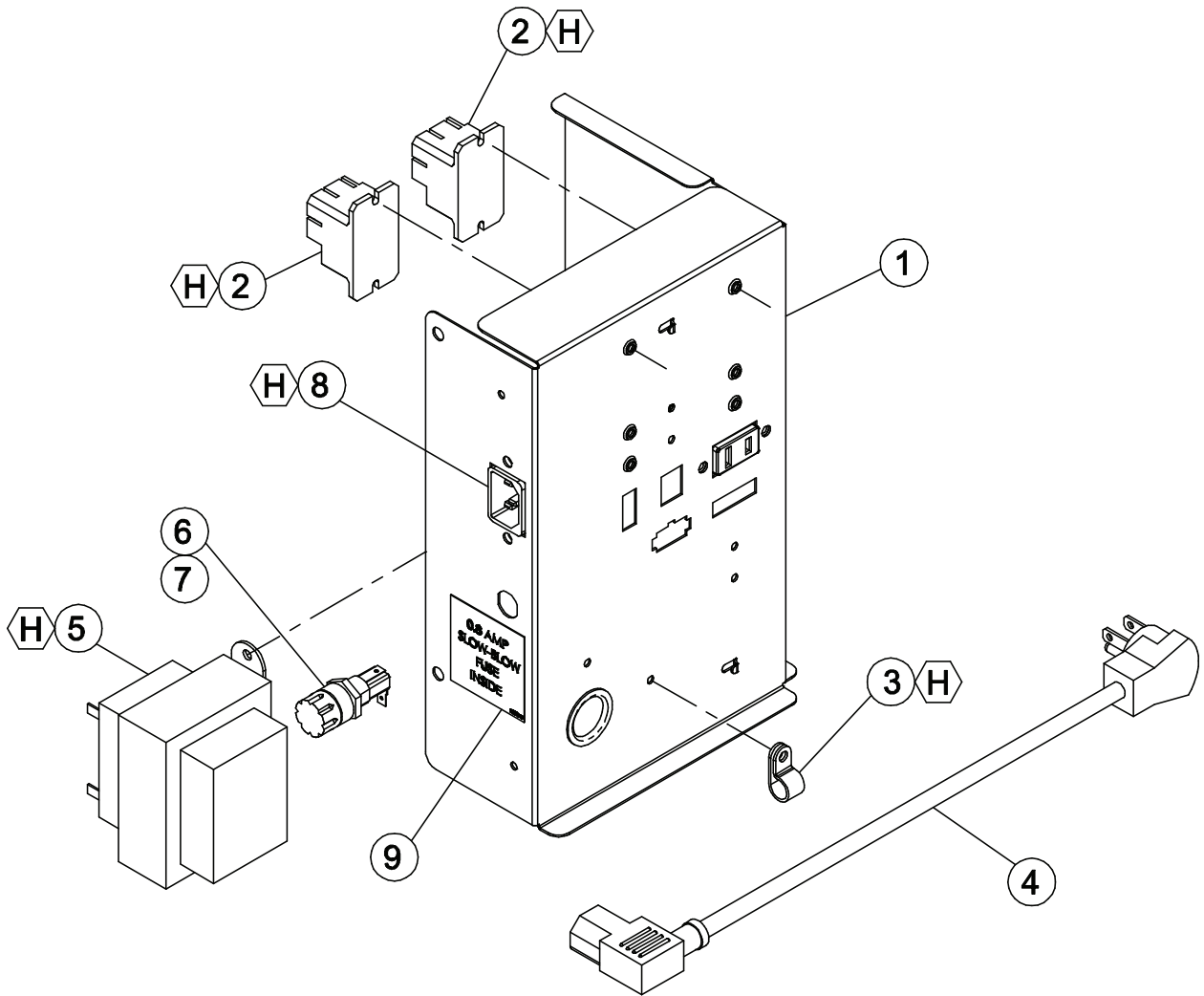



## POWER BOX ASSEMBLY

ITEM NO	DESCRIPTION	QTY REQ	PART NO.
1	POWER BOX HOUSING	1	1123448
2	RELAY	2	1124284
3	CLAMP	1	324099-3
4	CORDSET	1	1124281
5	TRANSFORMER	1	1111201
6	FUSEHOLDER	1	387966
7	0.8 AMP FUSE (NOT SHOWN)	1	1053864
8	POWER HARNESS	1	1123444
9	FUSE LABEL	1	1089546



## VENDO HARNESS QUICK REFERENCE GUIDE TRADE VENDORS

PART NO.	DESCRIPTION	PURPOSE	721	821	621
1122905	Door Harness	Connects motors, temp. sensors, transformer, drop sensors, and relays to the control board	X	X	X
1111287	Selection Harness - 10 select	Connects the selection buttons to the control board	X	X	N/A
1117872	Selection Harness - 8 select	Connects the selection buttons to the control board	N/A	N/A	X
1111252	Display Harness	Connects the display to the control board	X	X	X
1122918	Motor Harness - 10 select	Connects the vend motors to the door harness	X	X	N/A
1123050	Motor Harness - 8 select	Connects the vend motors to the door harness	N/A	N/A	X
1122193	Evaporator Fan Harness	Connects the evaporator fans to the power distribution box	X	X	X
1123444	Power Distribution Harness	Input for 110v service cord and output to compressor, evaporator, fans, control board, and transformer	X	X	X
1124065	Motor Harness w/ Pre-cool - 10 select	Connects the vend motors to the door harness	X	X	N/A
1124066	Motor Harness w/ Pre-cool - 8 select	Connects the vend motors to the door harness	N/A	N/A	X





NOTES